

Pressure gauge with plastic case

Designed to monitor pressure in systems not subjected to vibrations. Suitable for all gaseous and liquid media that will not obstruct the pressure system or attack copper alloy parts.

Especially designed for pneumatic circuits, filters, pressure regulators...
Manufactured according to EN 837-1 standards.

STANDARD PARAMETERS

Design: EN 837-1

Closing: Adjusted display

Mounting: See attached diagram A or B

Threaded connection: $\varnothing 40$: 1/8" BSPT; $\varnothing 50$ - $\varnothing 63$: 1/4" BSPT (UNE-EN 10226-1)

IP protection: IP44 (EN 60529 / IEC 529)

Accuracy: Class 2.5

Pressure limits:

Static: 3/4 end of scale

Oscillating: 2/3 end of scale

Maximum: Full scale for a short period of time

Temperature limits:

Environment: -40+60°C

Fluid: 60°C

Pressure range: -1...0...25 Bar

Scale: Bar/Psi

Subdivision: According to standard EN 837-1

Sensor: Bourdon tube ("C" form)

Position pointer: Red pointer (only for ranges 0+4/0+6/0+12)

MATERIALS

Case: Polyethylene

Bourdon tube and moving parts: Copper alloy

Threaded connection: Brass

Display: Acrylic

Dial: White laquered aluminum

Pointer: Black laquered aluminum

Welding: Cu-Sn

Red pointer: Red Plastic



Application:

- Compressed air
- Compressor
- Air conditioning
- Hydraulics
- Pneumatic

A Bottom

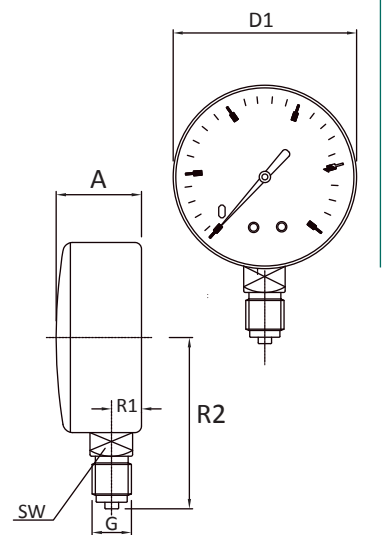

B Back

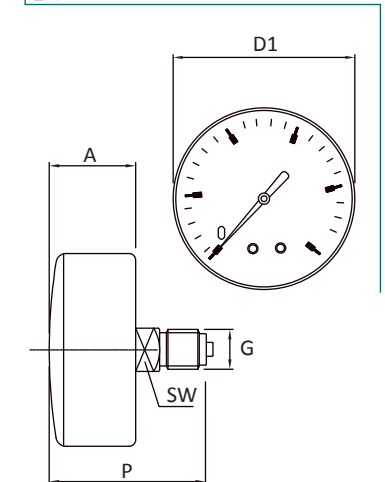

DIMENSIONS (mm)

WEIGHT (g)

DN	Mounting	R1	A	D1	G	R2	SW	P	WEIGHT (g)
$\varnothing 40$	A	8	25	40	1/8" BSPT	37	11	-	40
$\varnothing 40$	B	-	25	40	1/8" BSPT	-	11	39	45
$\varnothing 50$	A	8	27	53	1/4" BSPT	37	11	-	57
$\varnothing 50$	B	-	27	53	1/4" BSPT	-	11	47	73
$\varnothing 63$	A	8	27	63	1/4" BSPT	37	11	-	65
$\varnothing 63$	B	-	27	63	1/4" BSPT	-	11	47	79

How to order

1. Case diameter

$\varnothing 40$ $\varnothing 50$ $\varnothing 63$

2. Pressure range (Bar)

-1+0 0+2.5 0+6 0+12 0+25
0+1.6 0+4 0+10 0+16

3. Pressure Unit

Bar/Psi

4. Mounting

A **B**

5. Threaded connection

1/4" BSPT 1/8" BSPT

6. Connection material

Brass

7. Calibration certificate traceable to ENAC

7 points certificate
Without certificate

M0101 -

1	2	3	4	5	6	7
---	---	---	---	---	---	---

www.termometros.com

Order it online!

+34 94 676 63 64

info@termometros.com

Pressure gauge with case in carbon steel



Designed to monitor pressure in systems not subjected to vibrations. Suitable for all gaseous and liquid media that will not obstruct the pressure system or attack copper alloy parts.

Especially designed for pneumatic and hydraulic circuits.

Manufactured according to EN 837-1 standards.

STANDARD PARAMETERS

Design: EN 837-1

Closing: Adjusted

Mounting: See attached diagram A or B

Threaded connection: $\varnothing 63$: 1/4" BSP; $\varnothing 75$: 3/8" BSP; $\varnothing 100$: 1/2" BSP (UNE-EN 10226-1)

IP protection: IP54 (EN 60529 / IEC 529)

Accuracy: $\varnothing 63$ - $\varnothing 75$: Class 2.5 / $\varnothing 100$: Class 1.6

Pressure limits:

Static: 3/4 end of scale

Oscillating: 2/3 end of scale

Maximum: Full scale for a short period of time

Temperature limits:

Environment: -40+80°C

Fluid: 80°C

Range: -1...0...600 Bar

Scale: Bar/Psi

Subdivision: According to standard EN 837-1

Sensor element: Bourdon tube (<60 Bar: "C" form; >60 Bar: helical)

MATERIALS

Case: Carbon steel painted in black

Bourdon tube and moving parts: Copper Alloy

Threaded connection: Brass

Display: Glass

Dial: White laquered aluminum

Pointer: Black laquered aluminum

Welding: P<250 Bar: Cu-Sn; P>250 Bar: Cu-Ag



Application:

- Compressed air
- Compressor
- Air conditioning
- Hydraulics
- Pneumatics

A Bottom

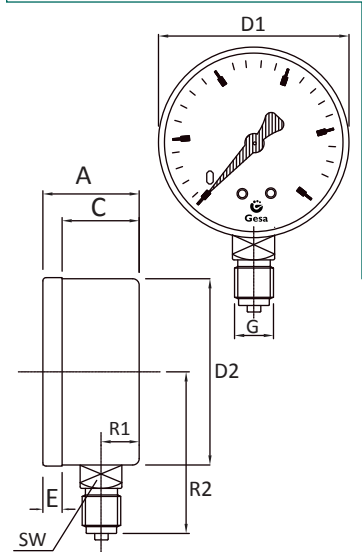

B Back

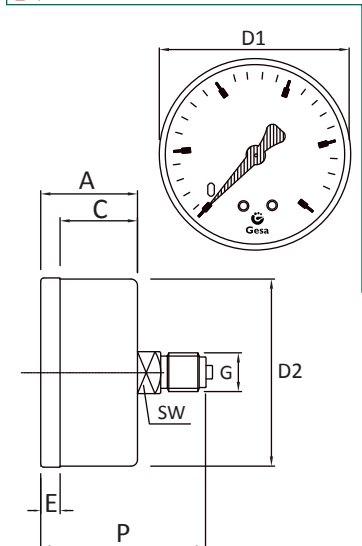

DIMENSIONS (mm)

WEIGHT(g)

DN	Mounting	R1	A	C	D1	E	D2	G	R2	SW	P	
$\varnothing 63$	A	10	28	17	40	10	62	1/4" BSP	51	14	-	110
$\varnothing 63$	B	-	28	17	40	10	62	1/4" BSP	-	14	46	122
$\varnothing 75$	A	10	30	19	53	11	74	3/8" BSP	60	17	-	165
$\varnothing 75$	B	-	30	19	53	11	74	3/8" BSP	-	17	55	170
$\varnothing 100$	A	16	45	23	63	22	98	1/2" BSP	83	17	-	383
$\varnothing 100$	B	-	45	23	63	22	98	1/2" BSP	-	17	75	405

How to order

1. Case diameter

$\varnothing 63$ $\varnothing 75$ $\varnothing 100$

2. Pressure range (Bar)

-1+0 -1+1.5 -1+5 -1+12 -1+24 0+1 0+2.5 0+6 0+16 0+40 0+100 0+250 0+400 0+1000
 -1+0.5 -1+3 -1+9 -1+15 0+0.6 0+1.6 0+4 0+10 0+25 0+60 0+160 0+315 0+600

3. Pressure scale

Bar/Psi

4. Mounting

A **B**

5. Threaded connection

1/4" BSP 1/2" BSP 3/8" BSP
 1/4" BSPT 1/2" BSPT 3/8" BSPT

6. Connection material

Brass

7. Calibration certificate traceable to ENAC

7 points certificate
 Without certificate

M0201 -

1	2	3	4	5	6	7
---	---	---	---	---	---	---

www.termometros.com



+34 94 676 63 64

info@termometros.com

Order it online!

Especially designed for difficult operating conditions like vibrations or rapid pressure changes. Suitable for use in systems with low viscosity that do not attack copper alloys such as cooling systems.
Manufactured according to EN 837-1 standards.

STANDARD PARAMETERS

- Design: EN 837-1
- Closing: Sealed ring
- Mounting: See attached diagram **A**, **B**, **C** or **D**
- Threaded connection: **Ø63**: ¼" BSP; **Ø80**: ⅜" BSP; **Ø100**: ½" BSP (UNE-EN 10226-1)
- IP protection: IP65 (EN 60529 / IEC 529)
- Accuracy: Class 1.6
- Pressure limits:
 - $P \leq 10$ bar: 125%
 - $10 < P \leq 160$ bar: 110%
 - $P > 160$ bar: 105%
- Temperature limits:
 - Environment: -20+50°C
 - Fluid: Brass connection: 80°C / Steel connection: 100°C
- Range: -1...0...1000 Bar
- Scale: Bar/Psi, Bar or cmHg
- Subdivision: According to standard EN 837-1
- Antivibration fluid: Glycerine 99.8%
- Sensor: Bourdon tube (<60 Bar: "C" form; >60 Bar: helical)
- Overtemperature relief system: Upper plug

MATERIALS

- Case: AISI 304 Stainless steel
- Bourdon tube and moving parts: Copper Alloy or AISI 316 Stainless steel
- Threaded connection: Brass or AISI 316 Stainless steel
- Display: Polycarbonate Thickness: **Ø63**: 2.8mm | **Ø80**: 3mm | **Ø100**: 3.5mm
- Dial: White laquered aluminum
- Pointer: Black laquered aluminum
- Welding: P<250 Bar: Cu-Sn; P>250 Bar: Cu-Ag / TIG Welding
- Overtemperature relief plug: Neoprene

Application:

- Ship supplies
- Irrigation systems
- Air conditioning
- Food industry
- Pneumatics
- Hydraulics

DIMENSIONS (mm)

WEIGHT (g)

DN	Mounting	R1	A	C	D1	E	D2	G	R2	SW	P	B1	B2	B3	WEIGHT (g)
Ø63	A/B	10	29	23	68	6	61	¼ BSP	56	14	-	86	80	3,5	188
Ø63	C/D	-	29	23	68	7	61	¼ BSP	-	14	58	86	80	3,5	184
Ø80	A/B	10	30	22	88	8	80	⅜ BSP	60	17	-	112	104	5	335
Ø80	C/D	-	30	22	88	8	80	⅜ BSP	-	17	61	112	104	5	299
Ø100	A/B	16	37	29	109	8	99	½" BSP	83	21	-	132	124	5	550
Ø100	C/D	-	37	29	109	8	99	½" BSP	-	21	77	132	124	5	547

A Bottom

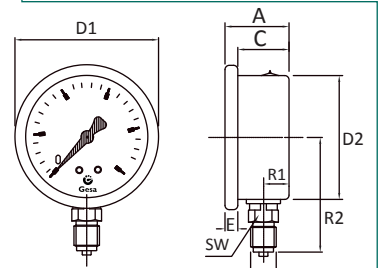

C Back

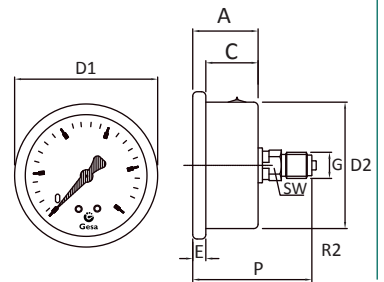

B Bottom with back flange

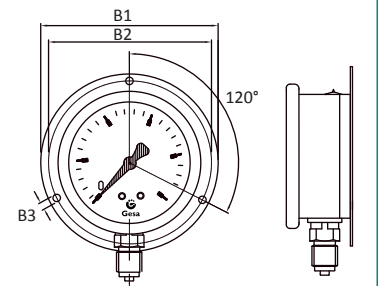

D Back with frontal flange

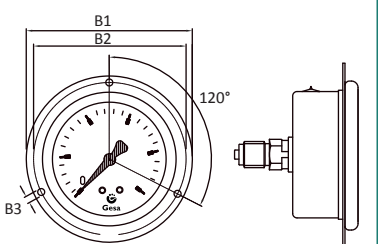

How to order

1. Case diameter

Ø63 Ø80 Ø100

2. Pressure range (Bar)

-1+0 -1+1.5 -1+5 -1+12 -1+24 0+1 0+2.5 0+6 0+16 0+40 0+100 0+250 0+400 0+1000
 -1+0.5 -1+3 -1+9 -1+15 0+0.6 0+1.6 0+4 0+10 0+25 0+60 0+160 0+315 0+600 -76+0

3. Pressure scale

Bar Bar/Psi cmHg

4. Mounting

A **B** **C** **D**

5. Threaded connection

¼" BSP ½" BSP ¾" BSP
 ¼" BSPT ½" BSPT ¾" BSPT
 ¼" SAE 7/16" SAE

6. Connection material

Brass
 AISI 316 Stainless steel

7. Antivibration fluid

Glycerine 99.8%

8. Calibration certificate traceable to ENAC

7 Points Certificate
 Without certificate

M0301 -

www.termometros.com

Order it online!

+34 94 676 63 64

info@termometros.com



M 03 04

Pressure gauge in stainless steel with bayonet closing



Suitable for all gaseous and liquid media that will not obstruct the pressure system or attack copper alloy parts. Especially designed for difficult conditions of use, as there are vibrations or quick changes of pressure. Manufactured according to standard **EN 837-1**



STANDARD PARAMETERS

Design: EN 837-1
Closing: Bayonet
Mounting: See attached diagram A, B, C or D
Threaded connection: Ø63: ¼" BSP; Ø100-Ø150: ½" BSP (UNE-EN ISO 228-1)
IP protection: IP65 (EN 60529 / IEC 529)
Accuracy: Ø63: Class 1.6; Ø100-Ø150: Class 1.0
Pressure limits:
Static: Full scale
Oscillating: 0.9 end of scale
Maximum: 1.3 end of scale for a short period of time
Temperature limits:
Environment: -20+50°C (Glycerine) / -20+80°C (dry)
Fluid: 80°C
Range: -1...0...1000 Bar
Scale: Bar/Psi, Bar or cmHg
Subdivision: According to standard EN 837-1
Antivibration fluid: Glycerine 99.8% or dry
Pointer: Micrometric adjustment
Sensor element: Bourdon tube (<60 Bar: "C" form; >60 Bar: helical)
Pressure relief system: Blow-out disc
Overtemperature relief system: Upper plug

MATERIALS

Case: AISI 304 Stainless steel
Bourdon tube and moving parts: Copper Alloy
Threaded connection: Brass
Display: Safety glass
Dial: White laquered aluminum
Pointer: Black laquered aluminum
Welding: P<250 Bar: Cu-Sn; P>250 Bar: Cu-Ag
Blow-out disc and overtemperature relief plug: Neoprene

Application

- Ship supplies
- Irrigation stems
- Air conditioning
- Food industry
- Pneumatic
- Hydraulics

A Bottom

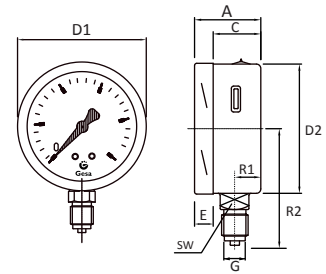

C Back

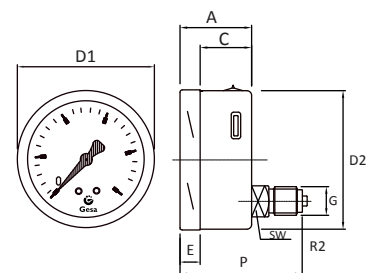

B Bottom with back flange

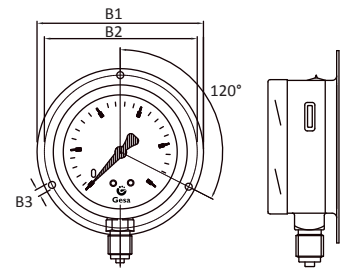

D Back with frontal flange

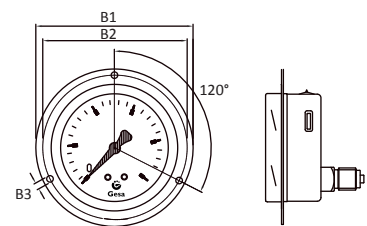

DN	Mounting	DIMENSIONS (mm)											WEIGHT (g)			
		R1	A	C	D1	E	D2	G	R2	SW	P	B1	B2	B3	Without Glycerine	With Glycerine
Ø63	A/B	10	34	22	64	12	62	¼ BSP	55	14	-	86	80	3,5	158	230
Ø63	C/D	-	34	22	64	12	62	¼ BSP	-	14	56	86	80	3,5	157	228
Ø100	A/B	16	49	32	101	17	99	½" BSP	83	22	-	132	124	5	533	867
Ø100	C/D	-	49	32	101	17	99	½" BSP	-	22	86	132	124	5	550	890
Ø150	A/B	16	50	32	149	18	146	½" BSP	113	22	-	192	184	5	950	1712
Ø150	C/D	-	50	32	149	18	146	½" BSP	-	22	87	192	184	5	824	1750

How to order

1. Case diameter

Ø63 Ø100 Ø150

2. Pressure range (Bar)

-1+0 -1+1.5 -1+5 -1+12 -1+24 0+1 0+2.5 0+6 0+16 0+40 0+100 0+250 0+400 0+1000
 -1+0.5 -1+3 -1+9 -1+15 0+0.6 0+1.6 0+4 0+10 0+25 0+60 0+160 0+315 0+600 **-76+0**

3. Pressure scale

Bar Bar/Psi cmHg

4. Mountin

A **B** **C** **D**

5. Threaded connectio

¼" BSP ½" BSP ¾" BSP
 ¼" BSPT ½" BSPT ¾" BSPT
 ¼" SAE 7/16" SAE M20x150

6. Connection material

Brass

7. Antivibration flu

Glycerine 99.8%
Without fluid

8. Calibration certificat traceable to ENAC

7 Points Certificate
Without certificate

M0304 -

1	2	3	4	5	6	7	8
---	---	---	---	---	---	---	---



+34 94 676 63 64

info@termometros.com

www.termometros.com
Order it online!



Especially designed for difficult operating conditions like vibrations or rapid pressure changes. Suitable for use in systems with low viscosity that do not attack copper alloys such as cooling systems.
Manufactured according to EN 837-1 standards.

STANDARD PARAMETERS

- Design: EN 837-1
- Closing: Sealed ring
- Mounting: See attached diagram **A**, **B**, **C** or **D**
- Threaded connection: **Ø63**: ¼" BSP; **Ø80**: ⅜" BSP; **Ø100**: ½" BSP (UNE-EN ISO 228-1)
- IP protection: IP65 (EN 60529 / IEC 529)
- Accuracy: Class 1.6
- Pressure limits:
 - $P \leq 10$ bar: 125%
 - $10 < P \leq 160$ bar: 110%
 - $P > 160$ bar: 105%
- Temperature limits:
 - Environment: -20+50°C
 - Fluid: 100°C
- Range: -1...0...1000 Bar
- Scale: Bar/Psi, Bar or cmHg
- Subdivision: According to standard EN 837-1
- Antivibration fluid: Glycerine 99.8%
- Sensor: Bourdon tube (<60 Bar: "C" form; >60 Bar: helical)
- Overtemperature relief system: Upper plug

MATERIALS

- Case: AISI 304 Stainless steel
- Bourdon tube and moving parts: AISI 316 Stainless steel
- Threaded connection: AISI 316 Stainless steel
- Display: Polycarbonate
- Dial: White laquered aluminum
- Pointer: Black laquered aluminum
- Welding: TIG Welding
- Overtemperature relief plug: Neoprene

Application:

- Ship supplies
- Irrigation systems
- Air conditioning
- Food industry
- Pneumatics
- Hydraulics

DIMENSIONS (mm)

WEIGHT (g)

DN	Mounting	R1	A	C	D1	E	D2	G	R2	SW	P	B1	B2	B3	WEIGHT (g)
Ø63	A/B	10	29	23	68	6	61	¼ BSP	56	14	-	86	80	3,5	188
Ø63	C/D	-	29	23	68	7	61	¼ BSP	-	14	58	86	80	3,5	184
Ø80	A/B	10	30	22	88	8	80	⅜ BSP	60	17	-	112	104	5	335
Ø80	C/D	-	30	22	88	8	80	⅜ BSP	-	17	61	112	104	5	299
Ø100	A/B	16	37	29	109	8	99	½" BSP	83	21	-	132	124	5	550
Ø100	C/D	-	37	29	109	8	99	½" BSP	-	21	77	132	124	5	547

A Bottom

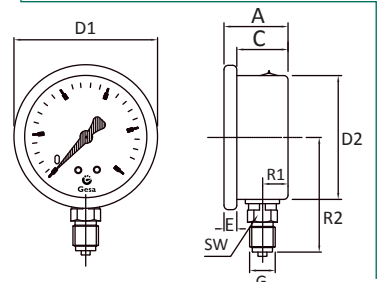

C Back

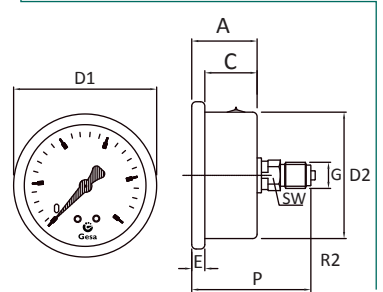

B Bottom with back flange

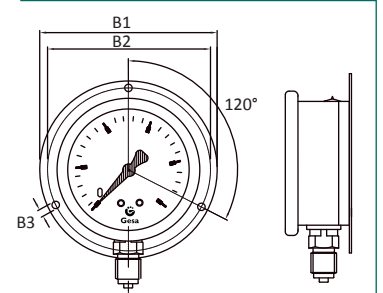

D Back with frontal flange

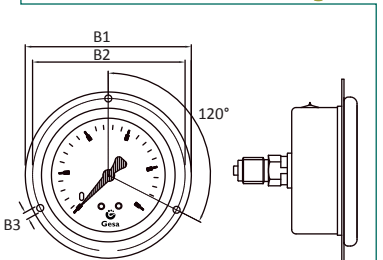

How to order

1. Case diameter

Ø63 Ø80 Ø100

2. Pressure range (Bar)

-1+0 -1+1.5 -1+5 -1+12 -1+24 0+1 0+2.5 0+6 0+16 0+40 0+100 0+250 0+400 0+1000
 -1+0.5 -1+3 -1+9 -1+15 0+0.6 0+1.6 0+4 0+10 0+25 0+60 0+160 0+315 0+600 -76+0

3. Pressure scale

Bar Bar/Psi cmHg

4. Mounting

A **B** **C** **D**

5. Threaded connection

¼" BSP ½" BSP ¾" BSP
 ¼" BSPT ½" BSPT ¾" BSPT
 ¼" SAE 7/16" SAE

6. Connection material

AISI 316 Stainless steel

7. Antivibration fluid

Glycerine 99.8%

8. Calibration certificate traceable to ENAC

7 Points Certificate
Without certificate

M0305 -

1	2	3	4	5	6	7	8
---	---	---	---	---	---	---	---

www.termometros.com

Order it online!

+34 94 676 63 64

info@termometros.com



M 03 06



Pressure gauge in stainless steel with bayonet closing

Suitable for all gaseous and liquid media that will not obstruct the pressure system or attack copper alloy parts. Especially designed for difficult conditions of use, as there are vibrations or quick changes of pressure. Manufactured according to standard **EN 837-1**

STANDARD PARAMETERS

Design: EN 837-1
Closing: Bayonet
Mounting: See attached diagram A, B, C or D
Threaded connection: Ø63: ¼" BSP; Ø100-Ø150: ½" BSP (UNE-EN ISO 228-1)
IP protection: IP65 (EN 60529 / IEC 529)
Accuracy: Ø63: Class 1.6; Ø100-Ø150: Class 1.0
Pressure limits:
Static: Full scale
Oscillating: 0.9 end of scale
Maximum: 1.3 end of scale for a short period of time
Temperature limits:
Environment: -20+50°C (Glycerine) / -20+80°C (dry)
Fluid: 100°C (Glycerine), 200°C (dry)
Range: -1...0...1000 Bar
Scale: Bar/Psi, Bar or cmHg
Subdivision: According to standard EN 837-1
Antivibration fluid: Glycerine 99.8% or dry
Pointer: Micrometric adjustment
Sensor element: Bourdon tube (<60 Bar: "C" form; >60 Bar: helical)
Pressure relief system: Blow-out disc
Overtemperature relief system: Upper plug

MATERIALS

Case: AISI 304 Stainless steel
Bourdon tube and moving parts: AISI 316 Stainless steel
Threaded connection: AISI 316 Stainless steel
Display: Safety glass
Dial: White laquered aluminum
Pointer: Black laquered aluminum
Welding: P<250 Bar: Cu-Sn; P>250 Bar: Cu-Ag / TIG Welding
Blow-out disc and overtemperature relief plug: Neoprene

Application:

- Ship supplies
- Irrigation systems
- Air conditioning
- Food industry
- Pneumatics
- Hydraulics

A Bottom

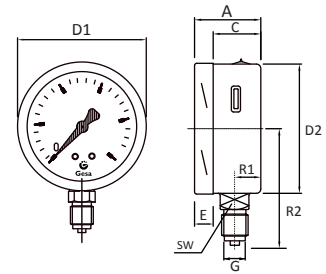

C Back

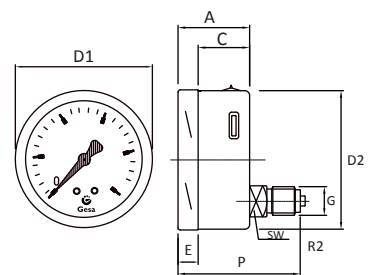

B Bottom with back flange

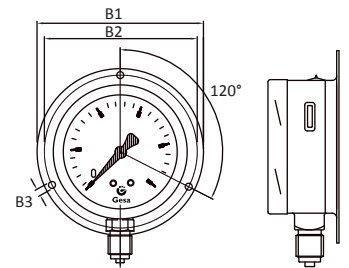

D Back with frontal flange

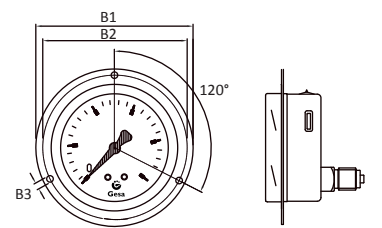

DN	Mounting	DIMENSIONS (mm)											WEIGHT (g)			
		R1	A	C	D1	E	D2	G	R2	SW	P	B1	B2	B3	Without Glycerine	With Glycerine
Ø63	A/B	10	34	22	64	12	62	¼ BSP	55	14	-	86	80	3,5	158	230
Ø63	C/D	-	34	22	64	12	62	¼ BSP	-	14	56	86	80	3,5	157	228
Ø100	A/B	16	49	32	101	17	99	½" BSP	83	22	-	132	124	5	533	867
Ø100	C/D	-	49	32	101	17	99	½" BSP	-	22	86	132	124	5	550	890
Ø150	A/B	16	50	32	149	18	146	½" BSP	113	22	-	192	184	5	950	1712
Ø150	C/D	-	50	32	149	18	146	½" BSP	-	22	87	192	184	5	824	1750

How to order

1. Case diameter

Ø63 Ø100 Ø150

2. Pressure range (Bar)

-1+0 -1+1.5 -1+5 -1+12 -1+24 0+1 0+2.5 0+6 0+16 0+40 0+100 0+250 0+400 0+1000
 -1+0.5 -1+3 -1+9 -1+15 0+0.6 0+1.6 0+4 0+10 0+25 0+60 0+160 0+315 0+600 -76+0

3. Pressure scale

Bar Bar/Psi cmHg

4. Mounting

A **B** **C** **D**

5. Threaded connection

¼" BSP ½" BSP ¾" BSP
 ¼" BSPT ½" BSPT ¾" BSPT
 ¼" SAE 7/16" SAE M20x150

6. Connection material

AISI 316 Stainless steel

7. Antivibration fluid

Glycerine 99.8%
Without fluid

8. Calibration certificate traceable to ENAC

7 Points Certificate
Without certificate

M0306 -



Capsule pressure gauges with elastic element and moving parts in copper alloy manufactured according to EN 837-3 standards.

Especially suitable for gaseous media not subjected to vibrations with a maximum temperature not higher than 100°C.



Application:

- Gas facilities
- Low pressure

STANDARD PARAMETERS

Design: EN 837-3
 Closing: Bayonet
 Mounting: See attached diagram **A**
 Threaded connection: **Ø63**: ¼" BSP; **Ø100**: ½" BSP (UNE-EN 10226-1)
 IP protection: IP43 (EN 60529 / IEC 529)
 Accuracy: **Ø63**: Class 1.6 / **Ø100**: Class 1.0
 Pressure limits:
 Static: Full scale
 Oscillating: 0.9 end of scale
 Maximum: Full scale
 Temperature limits:
 Environment: -40+80°C
 Fluid: 100°C
 Range: **0...600** mbar
 Scale: mbar
 Subdivision: According to standard EN 837-3
 Sensor element: Capsule
 Pointer: Micrometric adjustment

MATERIALS

Case: Carbon steel painted in black
 Capsule and moving parts: Copper Alloy
 Threaded connection: Brass
 Display: **Ø63**: Acrylic (Adjusted closing)/ **Ø100**: Glass (Bayonet closing)
 Dial: White laquered aluminum
 Pointer: Black laquered aluminum
 Welding: Cu-Sn

A Bottom Ø100

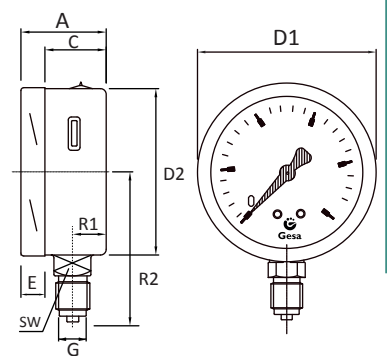

A Bottom Ø63

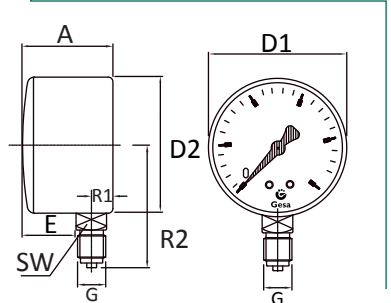

DIMENSIONS (mm)

WEIGHT (g)

DN	Mounting	R1	A	C	D1	E	D2	G	R2	SW	WEIGHT (g)
Ø63	A	11	38	-	66	22	66	¼ BSP	57	14	214
Ø100	A	16	49	32	101	17	99	½" BSP	83	22	559

How to order

1. Case diameter

Ø63 Ø100

2. Pressure range (Bar)

0+25 0+60 0+160 0+400
 0+40 0+100 0+250 0+600

3. Pressure scale

mbar

4. Mounting

A

5. Threaded connection

¼" BSP ½" BSP

6. Connection material

Brass

7. Calibration certificate traceable to ENAC

7 point certificate
 Without certificate

M0401 -

1	2	3	4	5	6	7
---	---	---	---	---	---	---

www.termometros.com

Order it online!

+34 94 676 63 64

info@termometros.com

Capsule pressure gauges with elastic element and moving parts in copper alloy manufactured according to **EN 837-3** standards.

Especially suitable for gaseous media not subjected to vibrations with a maximum temperature not higher than 100°C.



STANDARD PARAMETERS

Design: EN 837-3
Closing: Ring screwed to case
Mounting: See attached diagram A
Threaded connection: Ø63: ¼" BSP; Ø100: ½" BSP (UNE-EN 10226-1)
IP protection: IP44 (EN 60529 / IEC 529)
Accuracy: Class 1.6
Pressure limits:
Static: Full scale
Oscillating: 0.9 end of scale
Maximum: Full scale
Temperature limits:
Environment: -40+80°C
Fluid: 100°C
Range: 0...2000 mbar
Scale: mbar
Subdivision: According to standard EN 837-3
Sensor element: Capsule

MATERIALS

Case: Zinked carbon steel with screwed closing
Capsule and moving parts: Copper Alloy
Threaded connection: Brass
Display: Glass
Dial: White laquered aluminum
Pointer: Black laquered aluminum
Welding: Cu-Sn

Application:

- Gas facilities
- Low pressure

DIMENSIONS (mm)

WEIGHT (g)

DN	Mounting	R1	A	C	D1	E	D2	G	R2	SW	
Ø63	A	12	38	16	64	22	62	¼ BSP	59	11	198
Ø100	A	15	64	26	107	38	105	½" BSP	90	22	738

A Bottom

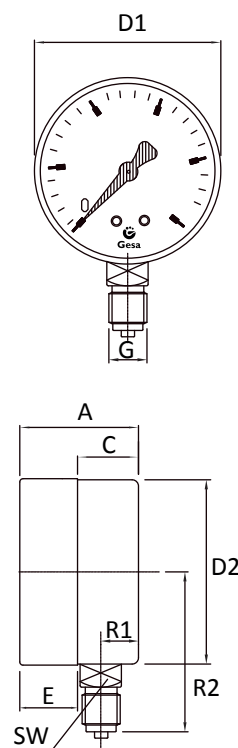

How to order

1. Case diameter

Ø63 Ø100

2. Pressure range (Bar)

0+25 0+60 0+160 0+400 0+1000
0+40 0+100 0+250 0+600 0+2000

3. Pressure scale

mbar

4. Mounting

A

5. Threaded connection

¼" BSP ½" BSP

6. Connection material

Brass

7. Calibration certificate traceable to ENAC

7 point certificate
Without certificate

M0402 -

1	2	3	4	5	6	7
---	---	---	---	---	---	---

www.termometros.com



Capsule pressure gauges with elastic element and moving parts in copper alloy manufactured according to EN 837-3 standards.

Especially suitable for gaseous media not subjected to vibrations with a maximum temperature not higher than 100°C.



STANDARD PARAMETERS

- Design: EN 837-3
- Closing: Bayonet
- Mounting: See attached diagram **A**
- Threaded connection: **Ø63**: ¼" BSP; **Ø100**: ½" BSP (UNE-EN 10226-1)
- IP protection: IP65 (EN 60529 / IEC 529)
- Accuracy: **Ø63**: Class 1.6 / **Ø100**: Class 1.0
- Pressure limits:
 - Static: Full scale
 - Oscillating: 0.9 end of scale
 - Maximum: Full scale
- Temperature limits:
 - Environment: -40+80°C
 - Fluid: 100°C
- Range: **0...600** mbar
- Scale: mbar
- Subdivision: According to standard EN 837-3
- Sensor element: Capsule
- Pointer: Micrometric adjustment

MATERIALS

- Case: AISI 304 Stainless steel with bayonet closing
- Capsule and moving parts: Copper Alloy
- Threaded connection: Brass
- Display: Safety glass
- Dial: White laquered aluminum
- Pointer: Black laquered aluminum
- Welding: Cu-Sn

Application:

- Gas facilities
- Low pressure

DIMENSIONS (mm)

WEIGHT (g)

DN	Mounting	R1	A	C	D1	E	D2	G	R2	SW	WEIGHT (g)
Ø63	A	10	37	27	74	10	66	¼ BSP	55	14	199
Ø100	A	16	49	32	101	17	99	½" BSP	83	22	545

A Bottom Ø100

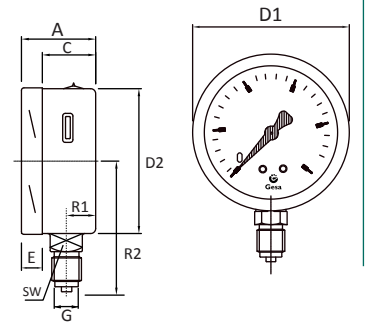

A Bottom Ø63

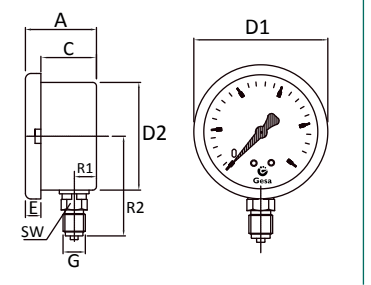

How to order

- | | | | |
|---|---|---|--------------------------------|
| 1. Case diameter
Ø63 Ø100 | 2. Pressure range (Bar)
0+25 0+60 0+160 0+400
0+40 0+100 0+250 0+600 | 3. Pressure scale
mbar | 4. Mounting
A |
| 5. Threaded connection
¼" BSP ½" BSP | 6. Connection material
Brass | 7. Calibration certificate traceable to ENAC
7 point certificate
Without certificate | |

M0403 -

1	2	3	4	5	6	7

www.termometros.com

Order it online!

+34 94 676 63 64

info@termometros.com

Pressure gauge for refrigeration systems with case in stainless steel



Suitable for all gaseous and liquid media that will not obstruct the pressure system or attack copper alloy parts.
Especially designed for difficult conditions of use, as there are vibrations or quick changes of pressure.
Also useful for adverse ambients. Manufactured according to EN 837-1 standards.



STANDARD PARAMETERS

Design: EN 837-1
Closing: Sealed ring
Mounting: See attached diagrams A, B, C or D
Threaded connection: $\varnothing 63$: 1/4" BSP; $\varnothing 100$: 1/2" BSP (UNE-EN 10226-1)
IP protection: IP65 (EN 60529 / IEC 529)
Accuracy: Class 1.6
Pressure limits:
Static: 3/4 end of scale
Oscillating: 2/3 end of scale
Maximum: Full scale for a short period of time
Temperature limits:
Environment: -20+50°C
Fluid: 80°C
Range: -1+12 or -1+24 Bar
Scale: Bar/R22/R134a/R404a/R507
Subdivision: According to standard EN 837-1
Antivibration fluid: Glycerine 99.8%
Sensor element: Bourdon tube ("C" form)
Overtemperature relief system: Upper plug

MATERIALS

Case and ring: AISI 304 Stainless steel
Bourdon tube and moving parts: Cu Alloy
Threaded connection: Brass
Visor: Polycarbonate
Dial: White laquered aluminum
Pointer: Black laquered aluminum
Welding: Cu-Sn
Overtemperature relief plug: Neoprene

Application:

- Refrigeration
- Air conditioning
- Food industry

A Bottom

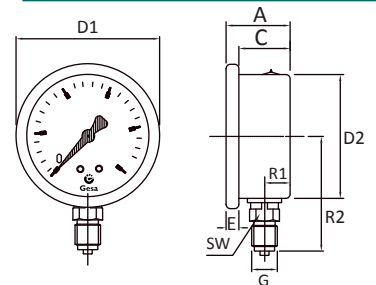

B Back

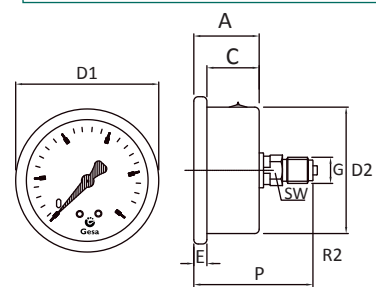

C Bottom with back flange

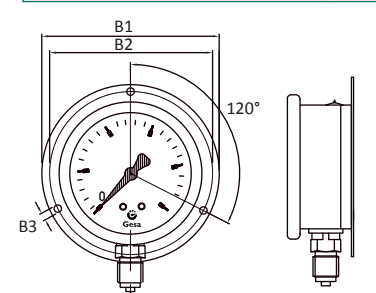

D Back with frontal flange

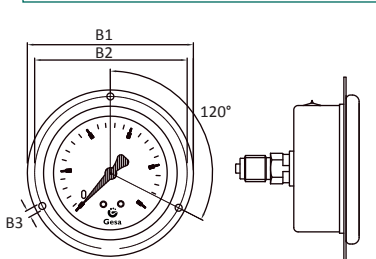

DIMENSIONS (mm)

WEIGHT (g)

DN	Mounting	R1	A	C	D1	E	D2	G	R2	SW	P	B1	B2	B3	WEIGHT (g)
$\varnothing 63$	A/C	10	29	23	68	6	61	1/4" BSP	56	14	-	86	80	3,5	180
$\varnothing 63$	B/D	-	29	23	68	6	61	1/4" BSP	56	14	58	86	80	3,5	180
$\varnothing 100$	A/C	12	37	29	109	8	99	1/2" BSP	87	21	-	132	124	5	607
$\varnothing 100$	B/D	-	37	29	109	8	99	1/2" BSP	87	21	77	132	124	5	607

How to order

1. Case diameter

$\varnothing 63$ $\varnothing 100$

2. Pressure range (Bar)

-1+12 -1+24

3. Pressure scale

Bar/R22/R134a/R404a/R507

4. Mounting

A B C D

5. Threaded connection

1/4" BSP 1/4" SAE 1/2" BSP

6. Connection material

Brass

7. Antivibration fluid

Glycerine 99.8%

8. Calibration certificate traceable to ENAC

7 point certificate
Without certificate

M0501 -

1	2	3	4	5	6	7	8
---	---	---	---	---	---	---	---

www.termometros.com



+34 94 676 63 64

info@termometros.com

Order it online!

Designed for refrigeration systems. Suitable for all liquid media that will not attack copper alloy parts.

Useful for systems where the gauge is not subjected to vibrations.

Manufactured according to EN 837-1 standards.



STANDARD PARAMETERS

Design: EN 837-1
Closing: Threaded Display
Mounting: Direct: free standing on the bottom connection
Threaded connection: $\varnothing 63$: 7/16"SAE; $\varnothing 100$: 1/2" BSP (UNE-EN 10226-1)
IP protection: IP43 (EN 60529 / IEC 529)
Accuracy: Class 1.6
Pressure limits:
Static: 3/4 end of scale
Oscillating: 2/3 end of scale
Maximum: Full scale for a short period of time
Temperature limits:
Environment: -40+80°C
Fluid: 80°C
Range: -1+12 or -1+24 Bar
Scale: Bar/R22/R404a/R507
Subdivision: According to standard EN 837-1
Sensor element: Bourdon tube ("C" form)

Application:

- Refrigeration
- Air conditioning
- Food industry

MATERIALS

Case: Carbon steel blue (-1+12 bar) or red (-1+24 bar)
Bourdon tube and moving parts: Cu Alloy
Threaded connection: Brass
Display and ring: Acrylic. Display and ring are a single piece threadable to the case
Dial: White laquered aluminum
Pointer: Black laquered aluminum
Welding: Cu-Sn

DIMENSIONS (mm) WEIGHT (g)

DN	Mounting	R1	A	C	D1	E	D2	G	R2	SW	WEIGHT (g)
$\varnothing 63$	A	11	30	19	72	11	68	3/8 BSPT	55	14	121
$\varnothing 100$	A	11	37	25	103	12	99	1/2 BSPT	80	14	241

A Bottom

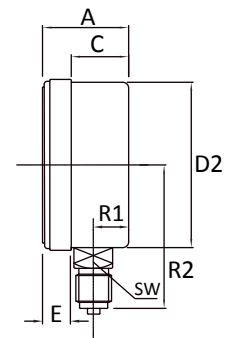
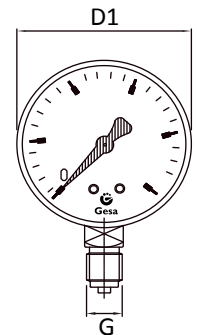

How to order

1. Case diameter

$\varnothing 63$ $\varnothing 100$

2. Pressure range (Bar)

-1+12 -1+24

3. Pressure scale

Bar/R22/R404a/R507

4. Mounting

A B

5. Threaded connection

1/2" BSP 7/16" SAE

6. Connection material

Brass

7. Calibration certificate traceable to ENAC

7 point certificate
Without certificate

M0502 -

1	2	3	4	5	6	7

www.termometros.com

Order it online!

+34 94 676 63 64

info@termometros.com

M 05 03

All stainless steel pressure gauge for refrigeration systems



Suitable for all gaseous and liquid media that will not obstruct the pressure system or attack copper alloy parts.

Especially designed for heavy duty conditions like vibrations or quick pressure changes. Manufactured according to EN 837-1 standards.



STANDARD PARAMETERS

Design: EN 837-1
Closing: Bayonet
Mounting: See attached diagrams A or B
Threaded connection: ½" BSP or ¼" SAE (UNE-EN 10226-1)
IP protection: IP65 (EN 60529 / IEC 529)
Accuracy: Class 1.0
Pressure limits:
Static: ¼ end of scale
Oscillating: ⅓ end of scale
Maximum: Full scale for a short period of time
Temperature limits:
Environment: -40+80°C
Fluid: 80°C
Range: -1+12 or -1+24 Bar
Scale: Bar/R22/R134a/R404a/R507
Subdivision: According to standard EN 837-1
Antivibration fluid: Glycerine 99.8% or dry
Sensor element: Bourdon tube ("C" form)
Overtemperature relief system: Upper plug

MATERIALS

Case: AISI 304 Stainless steel
Bourdon tube and moving parts: AISI 316 Stainless steel
Threaded connection: AISI 316 Stainless steel
Display: Safety glass
Dial: White laquered aluminum
Pointer: Black laquered aluminum
Welding: TIG welding
Overtemperature relief plug: Neoprene

Application:

- Refrigeration
- Air conditioning
- Food industry

A Bottom

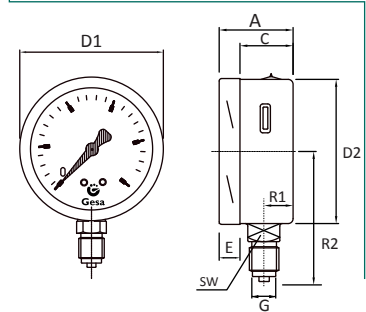

B Back

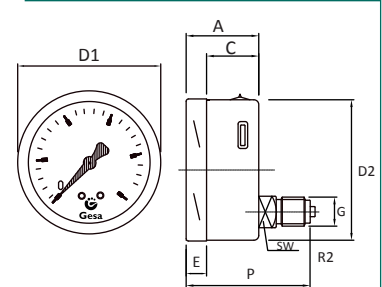

DIMENSIONS (mm)

WEIGHT (g)

DN	Mounting	R1	A	C	D1	E	D2	G	R2	SW	WEIGHT (g)
Ø100	A	16	49	32	101	17	99	½" BSP	83	22	575
Ø100	B	-	49	32	101	17	99	½" BSP	83	22	536

How to order

1. Case diameter

Ø100

2. Pressure range (Bar)

-1+12 -1+24

3. Pressure scale

Bar/R22/R134a/R404a/R507

4. Mounting

A B C D

5. Threaded connection

½" BSP ¼" SAE

6. Connection material

Brass
AISI 316 Stainless steel

7. Antivibration fluid

Glycerine 99.8%
Dry

8. Calibration certificate traceable to ENAC

7 point certificate
Without certificate

M0503 -

www.termometros.com



Gesa Termómetros S.L. - C/ Barrikako Bidea Pol. Ind. Igeltzera Pabellón D3 - 48610 Urduliz (Bizkaia) SPAIN



+34 94 676 63 64

info@termometros.com

Order it online!

ING1.0

Bourdon type pressure gauges completely ungreased for O₂ and acetylene.
 Manufactured according to **UNE-EN 562** standards.
 Working temperature is -40+60°C.
 Designed for system where fluid temperature does not exceed 60°C



STANDARD PARAMETERS

Design: UNE-EN 562
Closing: Threaded display
Mounting: See attached diagrams A or B
Threaded connection: Ø50: ¼" BSP ; Ø63: ¼" BSP (UNE-EN 562)
IP protection: IP44 (EN 60529 / IEC 529)
Accuracy: Class 2.5
Pressure limits:
Static: ¾ end of scale
Oscillating: ¾ end of scale
Maximum: Full scale for a short period of time
Temperature limits:
Environment: -40+60°C
Fluid: 60°C
Range: 0+2.5; 0+16; 0+40; 0+315 Bar
Scale: Bar
Subdivision: According to standard UNE-EN 562
Sensor element: Bourdon tube(<60 Bar: Type "C"; >60 Bar: helical)

MATERIALS

Case: Black laquered steel
Bourdon tube and moving parts: Copper Alloy
Threaded connection: Brass
Display and ring: Acrylic. Display and ring are a single piece threadable to the case
Dial: White laquered aluminum
Pointer: Black laquered aluminum
Welding: P<250 Bar: Cu-Sn; P>250 Bar: Cu-Ag

Application:

- Welding
- Oxygen
- Acetylene

DIMENSIONS (mm)

WEIGHT (g)

DN	Mounting	R1	A	C	D1	E	D2	G	R2	SW	P	
Ø50	A	10	28	17	57	12	52	¼ BSP	46	14	-	93
Ø50	B	-	28	17	66	12	52	¼ BSP	-	14	46	98
Ø63	A	10	29	17	57	12	61	¼ BSP	53	14	-	118
Ø63	B	-	29	17	66	12	61	¼ BSP	-	14	46	125

A Bottom

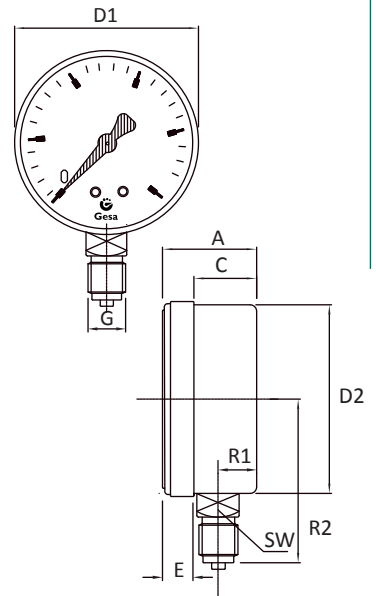

B Back

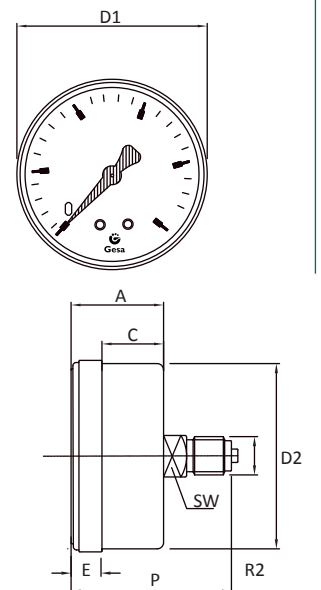

How to order

1. Case diameter	2. Pressure range (Bar)	3. Pressure scale	4. Mounting	5. Threaded connection
Ø50 Ø63	0+2.5 0+40 0+16 0+315	Bar	A B	¼" BSP
6. Connection material	7. Calibration certificate traceable to ENAC			
Brass	7 point certificate Without certificate			

M0601 -

1	2	3	4	5	6	7

www.termometros.com

Order it online!

+34 94 676 63 64

info@termometros.com

ING1.0



Suitable for all gaseous and liquid media that will not obstruct the pressure system or attack copper alloy parts. Useful for systems that are not subjected to strong vibrations.

Especially designed for pneumatics and hydraulics.

Manufactured according to EN 837-1 standards.



STANDARD PARAMETERS

Design: EN 837-1

Closing: Pressure adjusted

Mounting: See attached diagrams A or B

Threaded connection: 1/4" BSP (UNE-EN 10226-1)

IP protection: IP44 (EN 60529 / IEC 529)

Accuracy: Class 1.6

Pressure limits:

Static: 1/4 end of scale

Oscillating: 1/2 end of scale

Maximum: Full scale for a short period of time

Temperature limits:

Environment: -40+65°C

Fluid: 60°C

Range: -1+15 or -1+25 Bar

Scale: Bar/°C for refrigerant R717 (NH₃)

Subdivision: According to standard EN 837-1

Sensor element: Bourdon tube ("C" form)

MATERIALS

Case: Black laquered steel

Bourdon tube and moving parts: AISI 316 Stainless steel

Threaded connection: AISI 316 Stainless steel

Display: Acrylic

Dial: White laquered aluminum

Pointer: Black laquered aluminum

Welding: TIG welding

Application:

- Refrigeration
- Air conditioning
- Food industry

A Bottom

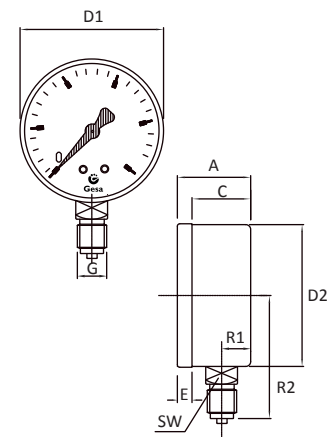

B Back

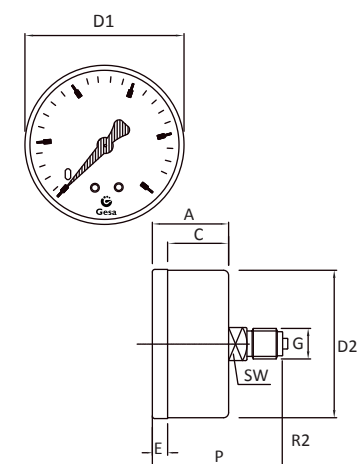

DIMENSIONS (mm)

WEIGHT (g)

DN	Mounting	R1	A	C	D1	E	D2	G	R2	SW	P	WEIGHT (g)
Ø63	A	11	28	18	63	10	62	1/4 BSP	52	14	-	122
Ø63	B	-	28	18	63	10	62	1/4 BSP	-	14	46	128

How to order

1. Case diameter

Ø63

2. Pressure range (Bar)

-1+15

-1+25

3. Pressure scale

Bar/°C R717 NH₃

4. Mounting

A

B

5. Threaded connection

1/4" BSP

6. Connection material

AISI 316 Stainless steel

7. Calibration certificate traceable to ENAC

7 point certificate
Without certificate

M0701 -

1	2	3	4	5	6	7
---	---	---	---	---	---	---

www.termometros.com

Order it online!

+34 94 676 63 64

info@termometros.com





Suitable for all gaseous and liquid media that will not obstruct the pressure system or attack copper alloy parts. Especially designed for refrigeration systems and ammonia.

Manufactured according to **EN 837-1** standards.

STANDARD PARAMETERS

Design: **EN 837-1**

Closing: Bayonet

Mounting: See attached diagrams **A** or **C**

Threaded connection: ½" BSP (UNE-EN 10226-1)

IP protection: IP65 (EN 60529 / IEC 529)

Accuracy: Class 1.0

Pressure limits:

Static: ¼ end of scale

Oscillating: ¾ end of scale

Maximum: Full scale for a short period of time

Temperature limits:

Environment: -40+65°C

Fluid: 60°C

Range: **-1+9, -1+12, -1+15** o **-1+25** Bar

Scale: Bar/ °C for refrigerant R717 (NH₃)

Subdivision: According to standard **EN 837-1**

Pointer: Micrometric adjustment

Sensor element: Bourdon tube (<60 Bar: "C" form; >60 Bar: helical)

Pressure relief system: Blow-out disc

Overtemperature relief system: Upper plug

MATERIALS

Case: AISI 304 Stainless steel

Bourdon tube and moving parts: AISI 316 Stainless steel

Threaded connection: AISI 316 Stainless steel

Display: Safety glass

Dial: White laquered aluminum

Pointer: Black laquered aluminum

Welding: TIG welding

Blow-out disc and overtemperature relief plug: Neoprene

Application:

- Refrigeration
- Air conditioning
- Food industry

A Bottom

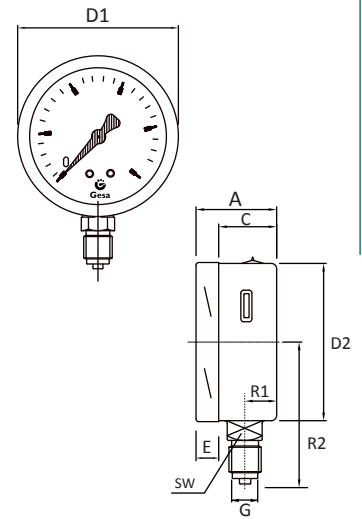

C Bottom with back flange

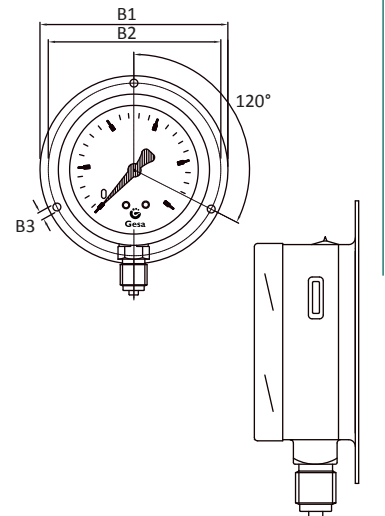

DIMENSIONS (mm)

WEIGHT (g)

DN	Mounting	R1	A	C	D1	E	D2	G	R2	SW	P	B1	B2	B3	Weight
Ø100	A	16	49	32	101	17	99	½" BSP	83	22	-	-	-	-	545
Ø100	C	16	49	32	101	17	99	½" BSP	83	22	86	132	124	5	566

How to order

1. Case diameter

Ø100

2. Pressure range (Bar)

-1+9
-1+12
-1+15
-1+25

3. Pressure scale

Bar/ °C R717 NH₃

4. Mounting

A **C**

5. Threaded connection

½" BSP

6. Connection material

AISI 316 Stainless steel

7. Calibration certificate traceable to ENAC

7 point certificate
Without certificate

ING1.0

M0702 -

1	2	3	4	5	6	7
---	---	---	---	---	---	---

www.termometros.com



M 08 01

Safety pressure gauge with phenolic case and solid front



The rugged phenolic case gives an excellent resistance to chemical agents, harsh weather and corrosion.

It is manufactured according to **EN 837-1, BS1780 y ASME B 40.1.**



STANDARD PARAMETERS

- Design: **EN 837-1, BS1780 y ASME B 40.1.**
- Closing: Safety closing
- Mounting: See attached diagram **A**
- Threaded connection: **½" BSP (UNE-EN 10226-1)**
- IP protection: **IP55 (EN 60529 / IEC 529)**
- Accuracy: Class 1.0 (first and last 25% of the scale) / 0.5 (rest of the scale)
- Pressure limits:
 - Static: Full scale
 - Oscillating: 90% end of scale
 - Maximum: 130% end of scale for a short period of time
- Temperature limits:
 - Environment: -40+60°C
 - Fluid: 60°C
- Range: **-1...0...1000 Bar**
- Scale: **Bar or Bar/Psi**
- Subdivision: According to standard **EN 837-1**
- Antivibration fluid: **Glycerine 99.8%, silicone oil or dry**
- Pointer: Micrometric adjustment
- Sensor element: Bourdon tube ("C" form)

Application:

- Petrochemistry
- Gas facilities

MATERIALS

- Case and ring: Phenolic resin (PBTB) / Polypropylene
- Bourdon tube and moving parts: AISI 316 Stainless steel
- Threaded connection: AISI 316 Stainless steel
- Display: Safety glass
- Dial: White laquered aluminum
- Pointer: Black laquered aluminum
- Welding: TIG welding

DIMENSIONS (mm)

WEIGHT (g)

DN	Mounting	D	D1	D2	D3	F	H	G	L	L1	SW	WEIGHT (g)
Ø125	A	142.5	127	136.7	7.6	-	179	½" BSP	81	-	22	409
Ø125	B	142.5	127	136.7	7.6	44.5	179	½" BSP	81	30	22	421

A Bottom

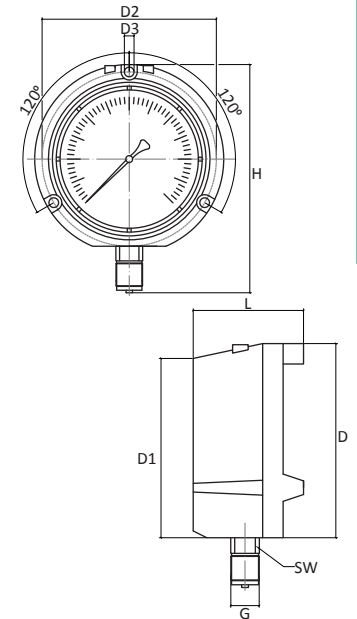

B Back

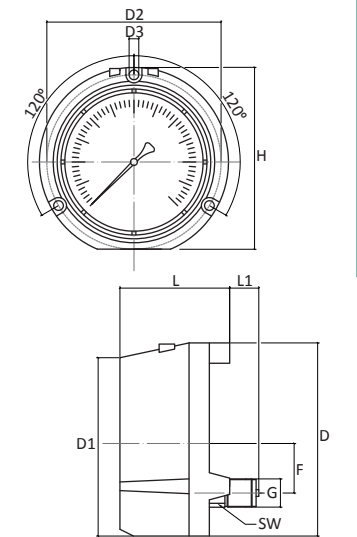

How to order

1. Case diameter

Ø125



-1+0	-1+5	-1+24	0+1.6	0+6	0+25	0+100	0+400
-1+0.6	-1+9	0+0.6	0+2.5	0+10	0+40	0+160	0+600
-1+3	-1+15	0+1	0+4	0+16	0+60	0+250	0+1000



3. Pressure scale

Bar
Bar/psi



4. Mounting

A **B**



5. Threaded connection

½" BSP



6. Connection material

Brass
Stainless steel/AISI 316



7. Antivibration fluid

Silicon oil
Glycerine
Dry



8. Calibration certificate traceable to ENAC

7 point certificate
Without certificate

M0801 -

1	2	3	4	5	6	7	8
---	---	---	---	---	---	---	---

www.termometros.com

+34 94 676 63 64

info@termometros.com

Order it online!



Gesa Termómetros S.L. · C/ Barrrikako Bidea Pol. Ind. Igeltzera Pabellón D3 · 48610 Urduliz (Bizkaia) SPAIN



ING1.0

Pressure gauges with diaphragm in AISI 316 Stainless steel. It is designed for high viscosity or corrosive fluids. Especially suitable for difficult operating conditions due to the existence of vibration or rapid pressure changes. Useful in harsh environments, and ammonia cooling systems.



STANDARD PARAMETERS

- Pressure gauge**
- Design: EN 837-1
- Closing: Bayonet
- Mounting: See attached diagram **A**
- Threaded connection: 1/2" BSP (UNE-EN 10226-1)
- IP protection: IP65 (EN 60529 / IEC 529)
- Accuracy: Class 1.0
- Pressure limits:
 - Static: 3/4 end of scale
 - Oscillating: 3/4 end of scale
 - Maximum: Full scale for a short period of time
- Temperature limits:
 - Environment: -40+65°C
 - Fluid: 60°C
- Range: 0...25 Bar
- Scale: Bar
- Subdivision: According to standard EN 837-1
- Antivibration fluid: **Glycerine 99.8% or dry**
- Pointer: Micrometric adjustment
- Sensor element: Bourdon tube ("C" form)
- Pressure relief system: Blow-out disc
- Overtemperature relief system: Upper plug

- Application:**
- Cooling
 - Air conditioning
 - Food
 - Treatment Plants
 - Hydraulic

Diaphragm
Temperature limit of the transmission liquid: Up to 200°C

MATERIALS

- Pressure gauge**
- Case and ring: AISI 304 Stainless steel
- Bourdon tube and moving parts: AISI 316 Stainless steel
- Threaded connection: AISI 316 Stainless steel
- Display: Safety glass
- Dial: White laquered aluminum
- Pointer: Black laquered aluminum
- Pressure gauge welding: TIG welding
- Blow-out disc and overtemperature relief plug: Neoprene

Diaphragm
Body: AISI 316 Stainless steel
Transmission liquid: Silicon oil
Bolts: AISI 316 Stainless steel

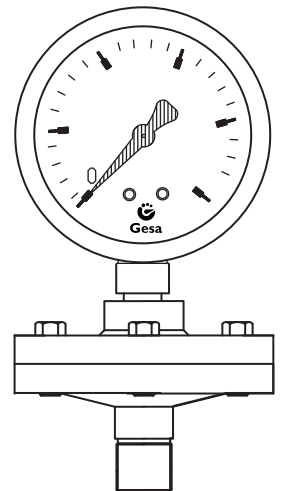
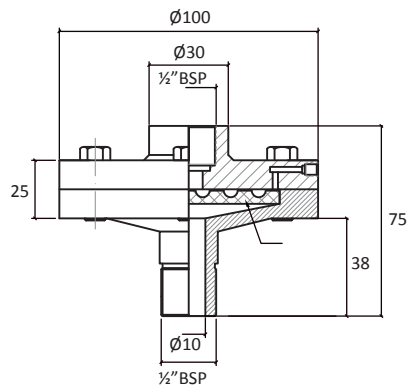
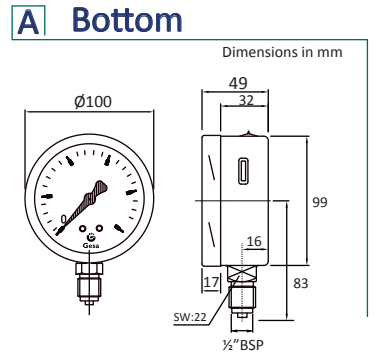

How to order

1. Case diameter	2.. Pressure range (Bar)	3. Pressure scale	4. Mounting	5. Threaded connection	6. Connection material	7. Antivibration fluid	8. Calibration certificate traceable to ENAC
Ø100	0+2.5 0+4 0+6 0+10 0+16 0+25	Bar	A	1/2" BSP	AISI 316 Stainless steel	Glycerine 99.8% Dry	7 point certificate Without certificate

SEP 101 -

1	2	3	4	5	6	7	8
---	---	---	---	---	---	---	---

www.termometros.com

Order it online!

+34 94 676 63 64

info@termometros.com

ING1.0



Vibrations

In systems subjected to severe vibrations it is necessary that the gauge pointer does not vibrate and prevent reliable pressure reading. To avoid it the manometer is filled with a liquid having certain viscosity which prevents the pointer vibration. The most common liquids are glycerine and silicon oil.



Glycerine or Silicon oil



Overpressure

In cases where the gauge must be installed in facilities subjected to great pressure. It is desirable to include a pressure limiting valve which prevents overpressure damaging the pressure gauge.



Pressure limiter



Pulsation

Processes in which significant increases and pressure drops require parts to cushion these sudden changes that can damage the instrument and cause leakage.



Damper pressure



Overheating

Temperatures in some of the systems subject to measurement can damage internal components of the gauge, so it is advisable to use heat sinks to ensure the operability of the instrument.

There are several accessories that meet this function, these are the most common.



Cooling tower



Coil damper



Capilar



Isolation

For installations where continuous pressure monitoring is not required, the use of valves to separate the pressure gauge system is recommended, either because the liquid can attack the internal parts in long exposures or because the use of the instrument alters the normal process operation.



Valve

Pressure limiter

The pressure limiter protects the instrument from pressures that exceed their limit of security.

They allow the use of specialized pressure gauges in systems with large pressure changes. The limiter can be adjusted to the maximum pressure by the pressure gauge and supported when it is exceeded the limiter blocks the duct protecting the pressure gauge.



STANDARD PARAMETERS

Maximum pressure supported: 600 Bar

Temperature of the fluid: -40 to 120°C

Instrument connection: ½" BSP Female

Process connection: ½" BSP Male

Degreased for O₂: Up to 50 Bar and 60°C

MATERIALS

Body and wetted parts: AISI 316 Stainless steel

Gasket/O-ring: Viton

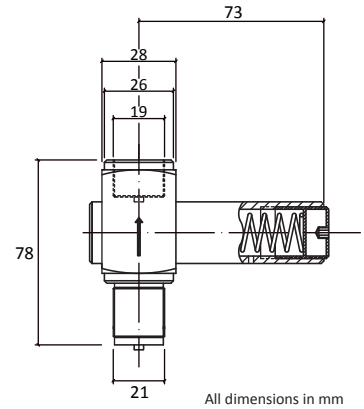

How to order

1. Model

Bellows (200 mbar to 4 Bar)
Piston (6 Bar to 400 Bar)

2. Degreased for O₂

Yes
No

M0901-

1

2

Cooling tower

Designed to protect the gauge of the high process temperatures. The air cools the liquid in contact with the surface



STANDARD PARAMETERS

Maximum pressure supported: 1000 Bar

Maximum working pressure: 300°C

Instrument connection: ¼" NPT Female

Process connection: ¼" NPT Male

MATERIALS

Body and wetted parts: AISI 316 Stainless steel

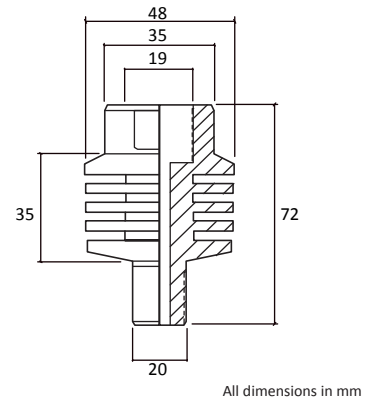

How to order

Reference: M0903

Cooling tower

Designed to protect the gauge of the high process temperatures. The air cools the liquid in contact with the surface



STANDARD PARAMETERS

Maximum pressure supported: 1000 Bar

Maximum working pressure: 300°C

Instrument connection: ¼" NPT Female

Process connection: ¼" NPT Male

MATERIALS

Body and wetted parts: AISI 316 Stainless steel

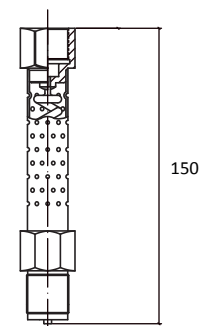

ING1.0

How to order

Reference: M0904





Coil damper

Designed to protect the gauge from media at high temperatures, like steam. Also to reduce the effect of sudden changes in pressure. For initial installation must fill the siphon with water or other equivalent liquid

STANDARD PARAMETERS

Maximum pressure supported: 600 Bar

Temperature of the fluid: -40 to 120°C

Instrument connection: Female

Process connection: Male

MATERIALS

Body and wetted parts: AISI 316 Stainless steel

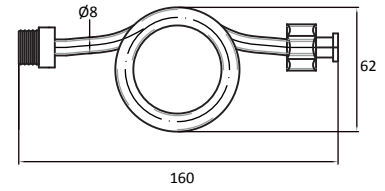

All dimensions in mm

How to order

1. Instrument connection / process

1/2" BSP Female / Male

1/4" BSP Female / Male

3/8" BSP Female / Male

M0902 -

1

Capillary extension

Designed to connect the gauge to a remote system and perform remote readings, it also cools the system's filling liquid providing protection to gauge. For installation it requires the measuring instrument available a flange or rim for paneling or a support for the extension



STANDARD PARAMETERS

Maximum pressure supported: 600 Bar

Temperature of the fluid: -40 to 120°C

Instrument connection: 1/4" BSP Female

Threaded connection: 1/4" BSP Male

Capillary length: 1m, 1.5m, 2m or 2.5m

MATERIALS

Body and wetted parts: AISI 316 Stainless steel

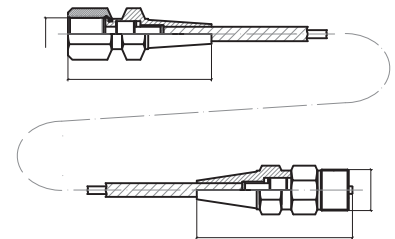

How to order

Reference: M0905

Pointer dampener

Designed to protect pressure measuring instruments from pulsating pressure applications. Sudden pressure changes are damped before they reach the sensing element, protecting it from high stress. It makes readings easier and prolongs the life of the instrument.

STANDARD PARAMETERS

Maximum pressure supported: 400 Bar (6000psi)

Temperature of the fluid: -25 to 200°C

Instrument connection: 1/2" BSP Female

Threaded connection: 1/2" BSP Male

MATERIALS

Body and wetted parts: AISI 316 Stainless steel or brass

Adjustment screw: AISI 316 Stainless steel Gasket: Viton

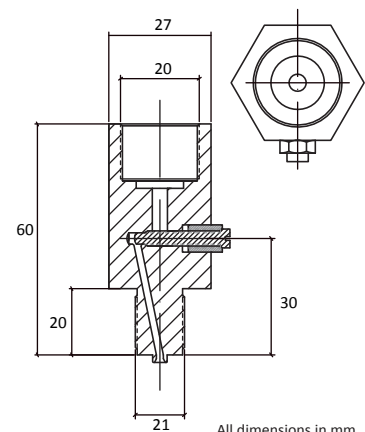

All dimensions in mm

How to order

Reference: M0906



The ball valves PN 20/25, have been constructed in accordance with the following European Standards:

- **UNE EN ISO 228**
- **UNE EN 22768**

The most frequent applications of the ball valve are opening/closing.

It is not advisable to use them in partially open service for a long time under conditions of high pressure drop across the valve.



STANDARD PARAMETERS

Structure: See attached diagrams **A** or **B**

Handle: Lever

Axis: Antileak system

IP protection: IP56

Usage limits:

Maximum nominal pressure: 20-25 bar

Working temperature: -20 to 150°C (Without steam)

Threaded connection: ¼" BSP, ⅜" BSP, ½" BSP, ¾" BSP, 1" BSP, 1 ¼" BSP, 1 ½" BSP or 2" BSP

MATERIALS

Body: Brass nickel plated

Handle: Stainless steel AISI 304 and plastic injected with rough texture.

Application:

- Plumbing
- Irrigation
- Pipes
- Circuits

A Female - Female

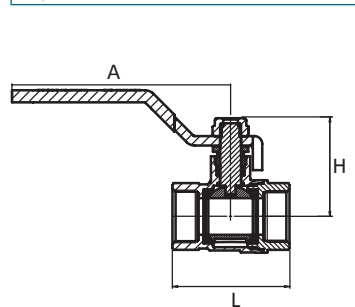

B Male - Female

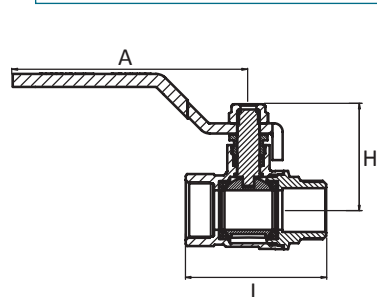

DIMENSIONS (mm)						WEIGHT (g)
Structure	Threads	Max PN	A	L	H	
Female - Female	¼" BSP	20 bar	83	36.7	31.5	126
	⅜" BSP	20 bar	83	39.8	31.5	147
	½" BSP	25 bar	83	43.6	37.9	153
	¾" BSP	25 bar	96	50	38.7	209
	1" BSP	25 bar	106	55.5	48.3	329
	1 ¼" BSP	25 bar	134	69.3	54	512
	1 ½" BSP	25 bar	141	78.3	67.5	737
	2" BSP	25bar	165	94	72.5	1160
Male- Female	¼" BSP	20 bar	85	42.9	31.5	130
	⅜" BSP	20 bar	85	43.7	31.5	153
	½" BSP	25 bar	83	49.3	37.9	162
	¾" BSP	25 bar	97	55.9	38.7	219

How to order

1. Structure

A **B**

2. Threaded connection

¼" BSP ¾" BSP 1 ½" BSP
 ⅜" BSP 1" BSP 2" BSP
 ½" BSP 1 ¼" BSP

V0125 -

1 _____ 2 _____

www.termometros.com



Order it online!

+34 94 676 63 64

info@termometros.com

Brass nickel plated Ball valve for pressure gauges

Useful to isolate the pressure gauge from the system.
The most common applications of this ball valve are opening and closing.
It is not recommended to use them in partly open services for long periods of time and under high pressure drops.



Application:

- Plumbing
- Irrigation
- Pipes
- Circuits

STANDARD PARAMETERS

Structure: See attached diagrams **A** or **B**

Handle: Lever

Axis: Antileak system

IP protection: IP56

Usage limits:

Maximum nominal pressure: 25 bar

Working temperature: -20 to 50°C (Without steam)

Threaded connection: ¼" BSP, ⅜" BSP or ½" BSP

MATERIALS

Body: Brass nickel plated

Handle: Polyethylene

A Female - Female

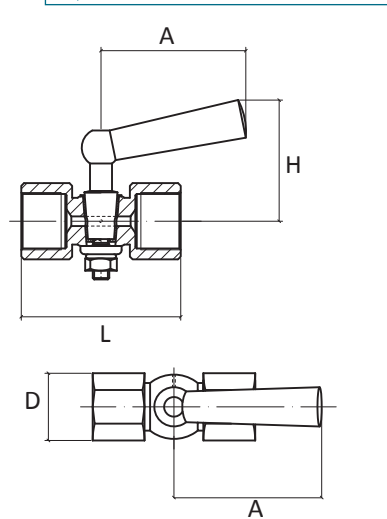

B Male - Female

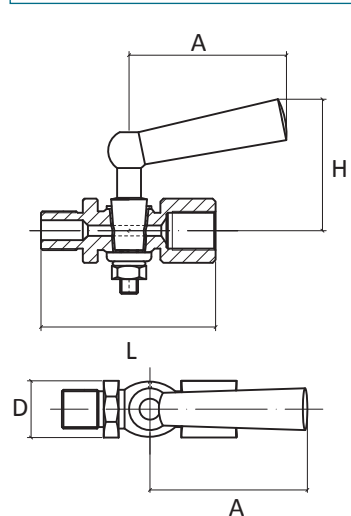

Structure	Threads	Max PN	DIMENSIONS (mm)				WEIGHT (g)
			A	L	H	D	
Female - Female	¼" BSP	25 bar	60	57.9	50	19	105
	⅜" BSP	25 bar	60	58.6	50	21.1	130
	½" BSP	25 bar	60	57.9	50	24.5	150
Male - Female	¼" BSP	25 bar	60	57.9	50	19	111
	⅜" BSP	25 bar	60	58.6	50	21.1	134
	½" BSP	25 bar	60	57.9	50	24.5	145

How to order

1. Structure

A **B**

2. Threaded connection

⇨ ¼" BSP ⅜" BSP ½" BSP ⇨

VP0325 -

1 _____ 2 _____

www.termometros.com



Order it online!

+34 94 676 63 64

info@termometros.com



Opening / Closing: The most common application of these Valves is in installations where the flow is interrupted regularly

It is not recommended to use them in partly open services for long periods of time and under high pressure drops.

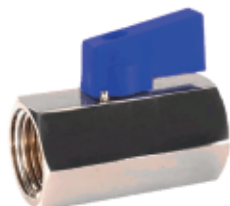

STANDARD PARAMETERS

Structure: See attached diagrams **A** or **B**

Handle: Short lever

IP protection: IP56

Usage limits:

Maximum nominal pressure: 16 bar

Working temperature: 0 to 90°C (Without steam)

Threaded connection: ¼" BSP, ⅜" BSP or ½" BSP

MATERIALS

Body: Chromed brass

Handle: Epoxy coated brass

Application:

- Plumbing
- Irrigation
- Pipes
- Circuits

A Female - Female

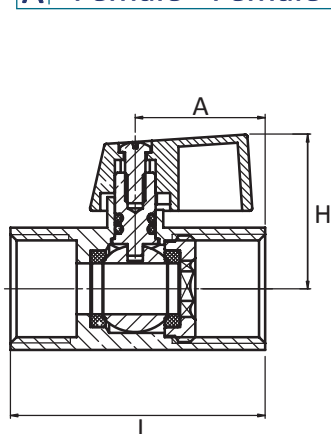

B Male - Female

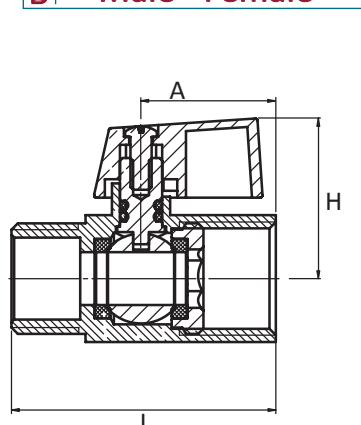

DIMENSIONS (mm)						WEIGHT (g)
Structure	Threads	Max PN	A	L	H	
Female - Female	¼" BSP	16 bar	23	43	28.5	110
	⅜" BSP	16 bar	23	44.5	28.5	110
	½" BSP	16 bar	26	50	30	125
Male - Female	¼" BSP	16 bar	23	44.5	28.5	95
	⅜" BSP	16 bar	23	44.5	28.5	95
	½" BSP	16 bar	25	50	28.5	114

How to order

1. Structure

A B

2. Threaded connection

¼" BSP ⅜" BSP 1 ½" BSP
 ⅝" BSP 1" BSP 2" BSP
 ⅜" BSP 1 ¼" BSP

MV0116 -



www.termometros.com



Order it online!

+34 94 676 63 64

info@termometros.com



CUJvfUjcb WfhZWHYg

The calibration process compares the output value of the instrument under calibration with a standard at different points of their scale, our standard consists in traceable patterns to ENAC (National accreditation entity).

During calibration the result of measuring instrument should be adjusted ,so that, it is put in accordance with the standard, to a specified accuracy. However, there are few instruments that can be adjusted until the perfect correspondence with the values given by the standards with which they are compared.

The results obtained are reported through our calibration certificate, which indicated a document identification code and detailed information about the instrument to calibrate, date, method of calibration, environmental conditions (temperature, humidity,...), the results and uncertainties obtained, and signature and accreditation of our laboratory.



Generally the calibration process is, in fact, comparison of an unknown value and a known one and the registration of the data obtained. Various reasons can lead to the need to calibrate an instrument:

- Realization of a new instrument calibration
- Expiration of the period of validity
- Depletion of certain volume of use (hours of work)
- Impacts or strong vibrations that descalibrate the instrument
- Whenever the observations obtained are questionable
- To comply with current regulations



We provide certificates for instruments of different :

- Certificates of 1 to 7 points
- Range for temperature - 30°C to 600°C
- Range for pressure - 1 to 600 bar
- Fast and flexible service.

Certificates to instruments not supplied by Gesa will require shipping the instrument to our facilities.
The usual deadline for issuing certificates is 5 days.





Gesa Termómetros, S.L.

Polígono Industrial Igeltzera

Pabellón D3

48610 Urduliz

Vizcaya, Spain



Distributed by:

info@termometros.com
www.termometros.com

Tel: +34 946 76 63 64